



Package
Passer

Bond Hill
SLCD-MAN
Drawer

Hamilton Walk-Up Drawers and Package Pass-Thru

Fast, efficient transfer of items
with maximum security.



HAMILTON
BY **GUNNEBO**®

Bond Hill SLCD & Package Pass-Thru

The Bond Hill SLCD Manual drawer is designed to pass small items between the customer and your employee. Built with rugged, highperformance stainless steel exterior for maximum security. Perfect for prescription containers and other small items.



Bond Hill
SLCD-MAN

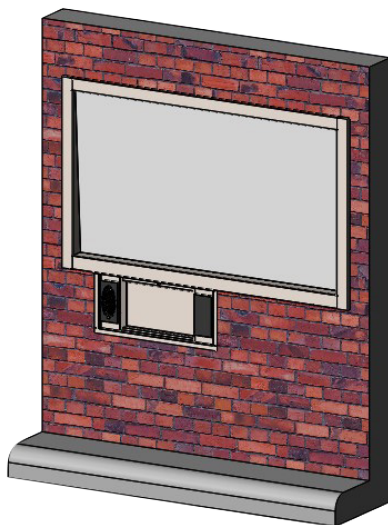

Hamilton's package pass-thru are designed to allow customers to securely pass items through a wall.



PRS-2 PACKAGE
PASS-THRU UNIT

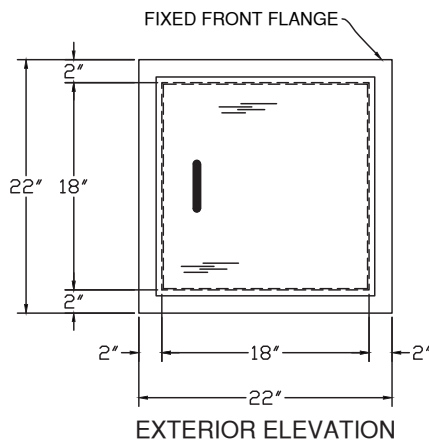

INNOVATIVE DESIGN BENEFITS

BOND HILL TRANSACTION DRAWER:

- DRAWER SIZE 6" H X 7" D X 15" W
- STAINLESS STEEL EXTERIOR FINISH
- ROTATING ARM EXTENDS DRAWER OUTWARD AND INWARDS
- AESTHETICALLY PLEASING
- BULLET RESISTANT

PACKAGE PASS-THRU UNITS:

- PRS-1 OPENING IS 12" x 12"; PRS-2 IS 18" x 18"
- STAINLESS STEEL EXTERIOR AND PAINTED INTERIOR
- SECURITY LOCKING DOORS SYSTEMS PREVENTS BOTH DOORS BEING OPENED SIMULTANEOUSLY
- CUSTOM SIZE UNITS AVAILABLE CONSULT FACTORY FOR DETAILS

FEATURES

BOND HILL TRANSACTION DRAWER:

- RELIABLE: CYCLED OVER ONE MILLION TIMES
- SECURE: LOCKABLE FOR AFTER HOURS
- BALLISTIC RATING: UL FOR LEVEL 3
- REACH: DRAWER EXTENSION ADJUSTABLE 7" TO 13 1/2"
- FINISH: STAINLESS STEEL AND BLACK LEATHERETTE
- LOW MAINTENANCE: SIMPLE MANUAL OPERATION
- ERGONOMIC: EASY AND COMFORTABLE TO OPERATE
- ENVIRONMENTAL: INNER DOOR SEALS AS OUTER DOOR OPEN
- OPTIONS: HEATER, VEHICLE DETECTION, PLUG & PLAY AUDIO, AND VIDEO

PACKAGE PASS-THRU UNITS:

- BUILT WITH MAXIMUM SECURITY
- EASY TO TRANSFER LARGE, BULKY ITEMS
- INCREASES SAFETY FOR CUSTOMERS AND STAFF DURING TRANSFER
- LITTLE OR NO MAINTENANCE REQUIRED

HAMILTON
BY GUNNEBO®

